



climacube™ PRIME

Drives heat up and energy cost down

REVOLUTIONARY
ENERGY SAVING
WATER HEATING SYSTEMS

SPAS | HOT TUBS | SWIMSPAS | SWIMMING POOLS



ENERGY SAVING TECHNOLOGY

Climacube design, develop and produce ground breaking, energy efficient Hot Tub, Spa, Swimspa and Swimming Pool Water Heating Systems. Utilising patented thermodynamic technology that dramatically reduces the power consumption required to heat or maintain heat over conventional heating systems. Saving up to 60% time on heat up and up to 80% less power. Saving customers time, energy and money, while significantly reducing their carbon footprint.

With hundreds of installations across the UK, our landmark Climacube products have been recognised by the industry, winning the converted UK Pool & Spa Awards 'Spa Product of the Year 2019' and 'Energy Efficient Product of the Year 2019'. Providing a ringing endorsement of our revolutionary Climacube water heating technology and its money saving benefits.

RELIABLE THERMODYNAMIC WATER HEATING SOLUTIONS

The Climacube range has undergone rigorous evaluation throughout the design and production process at our purpose built factory-testing facility. Which can accurately produce a working environment temperature range of 40 degrees to -25 degrees if required. By replicating accurate working conditions ensures our brands are market leaders. Solving any performance or reliability issues for our customers on test rather than in situ and allows Climacube to guarantee quality with our industry leading warranties.

We believe it is this attention to detail, investment in the highest quality testing facility and production control procedures, ensures our groundbreaking and innovative products are of the utmost quality and reliability.

REDUCES YOUR CARBON FOOTPRINT

By dramatically reducing the energy required to heat your Hot Tub, Spa, Swimspa or Swimming Pool will result in much lower power usage on heat up and continuous use, dramatically reducing the impact on the environment. The Climacube has full CE European Accreditation and A+ EPC Certification



SAVE ENERGY TIME AND MONEY

SPECIFICALLY DESIGNED FOR ORGANISATIONS WITH
MULTI INSTALLATIONS OF HOT TUBS OR SWIM SPAS



CLIMACUBE PRIME

The award winning Climacube Prime Water Heating System offers the very latest energy saving heat technology, dramatically reducing running costs, increasing customer usage, reducing your carbon footprint and enabling customers to enjoy the Hot Tub, Spa, or Swimspa all year round, at the desired temperature without the concern of cost. Unlike conventional heat systems, Climacube will heat hot tub or spa in around 4-5 hours from cold with a consumption of only 1KW per/hour with a COP of over 3.5 in minus temperatures – meaning a dramatic reduction in your annual energy costs.

Available as a stand-alone unit the Climacube can be retro- fitted or included as a pre-installed feature if required. Based on a thermo-dynamic patented technology, working off a 13 amp supply the revolutionary Climacube is supplied with all the appropriate European wide accreditations and is supplied, serviced and available throughout Europe.



ENERGY SAVING
TECHNOLOGY



SAVES ENERGY, TIME AND
MONEY



REDUCES YOUR CARBON
FOOTPRINT



NEW AND RETRO FIT
INSTALLATION OPTIONS

- 1 CLIMACUBE
- 2 FILTER
- 3 PUMP
- 4 BALL VALVE
- 5 ELECTRIC HEATER
- 6 HOT TUB

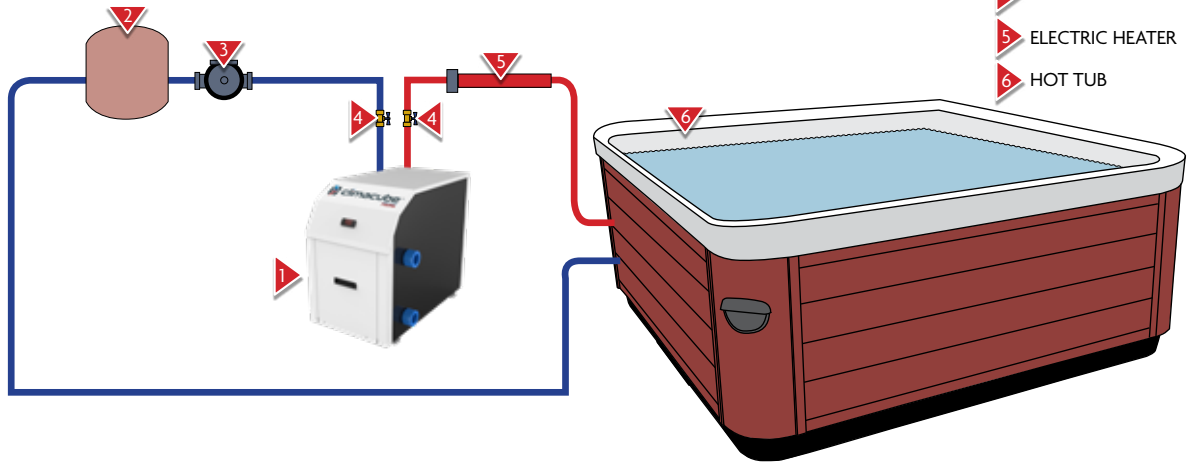

TECHNICAL FEATURES

Model	CCB04
Nominal thermal power (1) W	6.343
Nominal input power (1) W	1.580
COP (1)	4,01
Nominal thermal power (2) W	7.787
Nominal input power (2) W	1.568
COP (2)	4,96
Minimum air temperature °C	-5
Maximum water temperature HP °C	38
Refrigerant	R407C
Power supply, V/ph/Hz	230 / 1 / 50
Air flow m3/h	1300
Maximum pressure loss, Pa	100
Air exhaust connection, mm	160



ADVANCED CONTROLLED

- Suitable to any SPA installation, simple to set up and easy to use.
- Can be controlled by the hot tub electronics to achieve the maximum savings according to the customer's needs.
- Outlet air is around 10-15 °C lower than inlet temperature.
- Touch panel
- Intuitive and easy to use
- Anti-freeze protection
- Efficient defrosting

1) Air temperature 7 °C / Water temp. 35 °C
 2) Air temperature 15 °C / Water temp. 35 °C

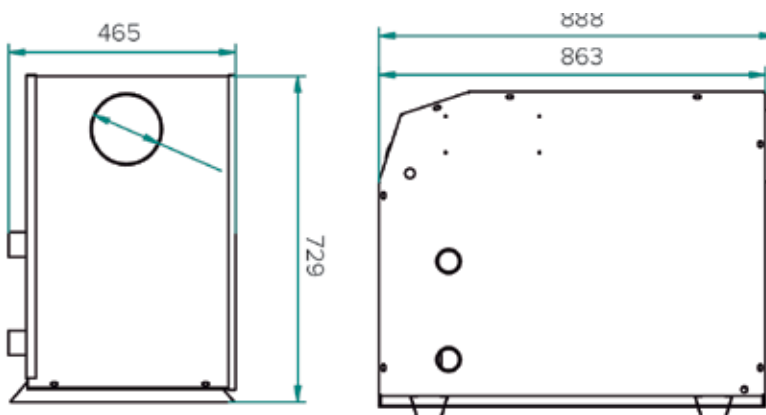



CLIMACUBE PRIME PERFORMANCE DATA SHEET

				STANDARD 3kW HEATER ELEMENT		CLIMACUBE HEAT SYSTEM ONLY		SAVING TIME & MONEY			
				3kW IN 3kW OUT		1kW IN 7kW OUT	1kW HEAT UP	TIME SAVING	% SAVING TIME	MONEY SAVING	% SAVING MONEY
HOT TUB MODEL	WATER TEMP C°	VOLUME WATER ltr	HEATING kW REQUIRED	HEATING HRS REQUIRED	COST 3kW .14p p.kW .42p	CLIMACUBE HEAT HRS	COST £ .14p	HRS		PER HOUR	
201 3 SEAT 7' X 5'5"	7	870	31.6	10.5	£4.41	4.5	£0.63	6	58%	£3.78	85%
	10	870	28.6	9.53	£4.00	4.0	£0.56	5.5	57%	£3.44	86%
202 4 SEAT 6'6" X 6'5"	7	1108	40.1	13.36	£5.61	5.7	£0.80	7.66	58%	£4.81	86%
	10	1108	36.3	12.1	£5.08	5.2	£0.73	6.9	57%	£4.35	86%
203 6 SEAT 7' X 7"	7	1288	51.3	17.1	£7.18	7.3	£1.02	9.8	57%	£6.16	85%
	10	1288	42.3	14.1	£5.92	6.0	£0.84	8.1	58%	£5.08	85%
204 7 SEAT 7' X 7'	7	1400	50	16.66	£6.99	7	£0.98	9.66	57%	£6.01	86%
	10	1400	46	15.3	£6.42	6.5	£0.91	8.8	57%	£5.51	86%
S106 8 SEATS 7'8" X 7'8"	7	1590	57.8	19.26	£8.09	8.3	£1.16	10.96	57%	£6.93	86%
	10	1590	52.2	17.4	£7.30	7.5	£1.05	9.9	57%	£6.30	86%

The performance data contained within this document has been achieved by controlled testing of the Climacube Commercial Heating System against a standard 3kW Heater Element installed in the Park Leisure Solutions Hot Tub Range. The results illustrate the compared performances of heating contained water from a standing temperature of 7 degrees C and 10 degrees C to a operating temperature of 36 degrees C for the following: A current, standard specification, commercially available 3kW Heater Element and a Climacube Heating System. The performance data contained in this document is for comparison purposes only and does not form part of any contractual agreement. Copyright Park Leisure Solutions Limited 2018



PERFORMANCE

Climacube uses award winning, energy saving, worldwide patented thermodynamic technology. Designed to deliver fast heat up, lower running cost and reduced carbon footprint.

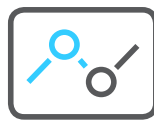

EASY INSTALLATION

Climacube can be installed from new or retro fitted to the Hot Tub, Spa, Swimspa or Pool, as a complete water heat solution, alternatively working in conjunction with the existing equipment.



SUPPLY & SERVICE

Fully tested and CE approved the Climacube Water Heating Systems include Europe wide products and parts warranty plus 12 month back to bench warranty for peace of mind.